

## IMP 270-F18 GEAR-TYPE TUBE BENDER

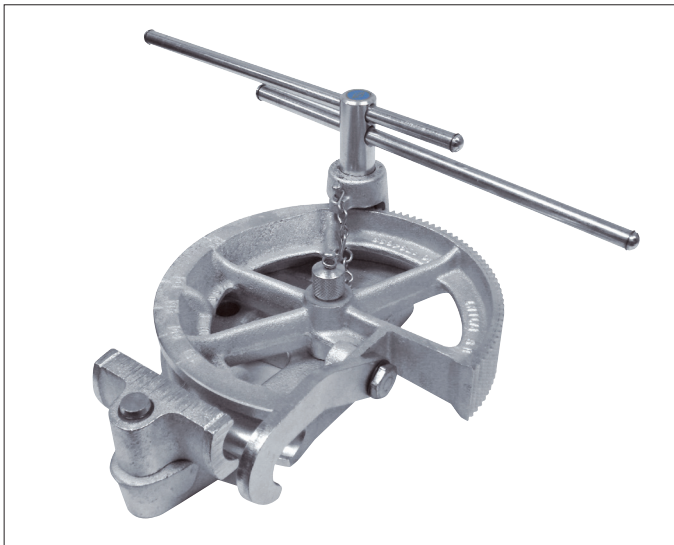

**3/8" to 1-1/8" O.D. tubing for bending soft and half-hard copper, aluminium brass, steel and other tubing and pipe which had been tempered and is suitable for bending.**

For all bending work. Spur-gear type with 10-to-1 ratio for easy bending of tempered tubing. Floating shoe aligns tube perfectly on calibrated forming wheel. Pull-pin on wheel speeds repositioning for bends over 90°. Portable. Can be hand held, clamped in vise or bolted to bench. Adapts to pipe vise with handle 271-F.

### FEATURES

- For 3/8" to 1-1/8" O.D. tubing.
- For all bending work
- Spur-gear type with 10-to-1 ratio for easy bending of tempered tubing
- Floating shoe aligns tube perfectly on calibrated forming wheel
- Pull-pin on wheel speeds repositioning for bends over 900
- Portable
- For use on a fixed or portable work bench and vice

NB: If not fixed to a bench or vice, bender or pipe must be fixed.

### PARTS

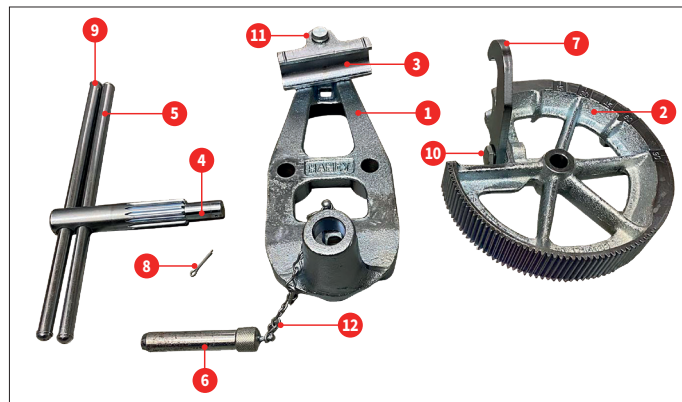

- |                         |                |                   |
|-------------------------|----------------|-------------------|
| 1. Gear bender body     | 5. Handle      | 9. Spring ring    |
| 2. Geared forming wheel | 6. Fulcrum pin | 10. Shoulder Bolt |
| 3. Shoe                 | 7. Hook        | 11. Spring ring   |
| 4. Splined shaft        | 8. Split pin   | 12. Chain         |

### SPECIFICATIONS

Code	Tube O.D.	Radius to centre of tube	Min. return from centre to centre of tube	Weight	Wall thickness
IMP-270-F18-KIT	92mm / 1-1/8"	101.6 mm / 4"	241.3mm / 9-1/2"	6.7kg / 14.75lbs	1.7 to 2.4mm* / .065 to .095"*

\* Not recommended for Type L Hard and Type M copper tubing with wall thickness over 1.65mm / .065"

### IN THE KIT

- Case
- Lubricant
- Enhanced instructions

**TOOLS**  
**IMP 270-F18 KIT**  
 GEAR-TYPE TUBE BENDER

The DiversiTech (Global) sales team are available to answer your questions or queries on this product. Our experts are waiting for your call +44 (0)115 900 5858 or if you prefer send an email to [sales@pumph.co.uk](mailto:sales@pumph.co.uk) or visit [www.pumph.co.uk](http://www.pumph.co.uk)

**DIVERSITECH**  
 (Global)